

Liste de pièces de rechange

STAR LIFTKET

Palans électriques à chaîne





LIFTKET Hoffmann GmbH

Dresdener Straße 64-68

04808 Wurzen / Germany

 +49-3425-89 24-0

 +49-3425-89 24-99

 sales@liftket.de

 www.liftket.de

Ho 01/2018 français

Aperçu

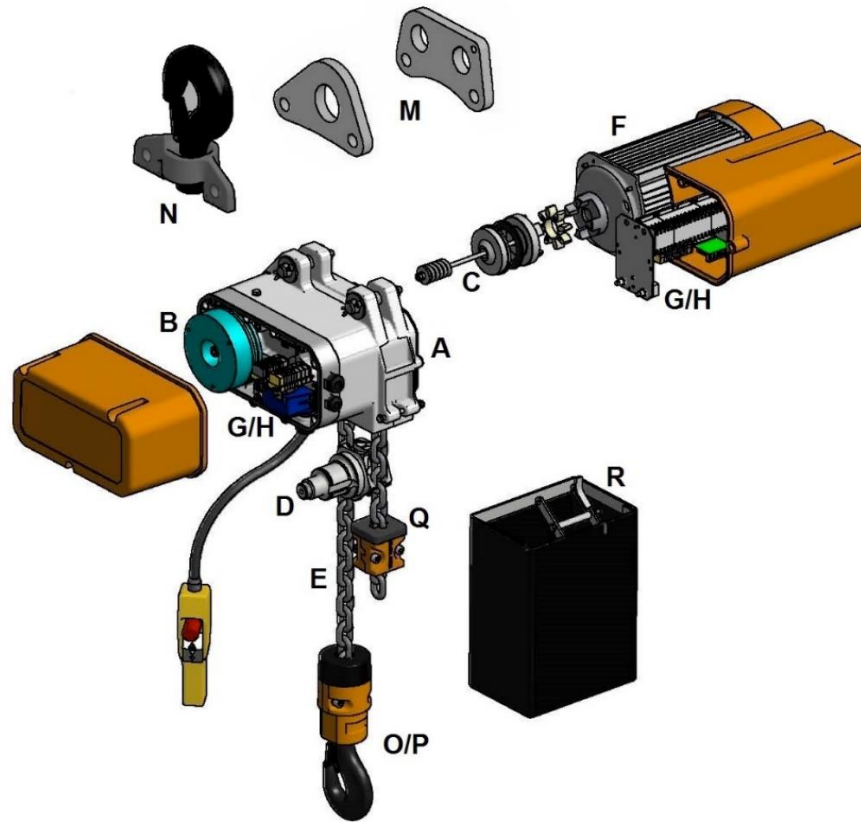

Code	Dénomination	Page
A	Boîtier	4
B	Frein	8
C	Embrayage	9
D	Arbre d'entraînement de la chaîne	11
E	Chaîne	13
F	Moteur	14
G	Commande directe	16
H	Commande circuit auxiliaire	21
J	Interrupteur de fin de course électrique	27
M	Œillets de suspension	28
N	Suspension à crochet	29
O	Moufle à crochet	30
P	Crochet de levage	31
Q	Limiteur de levage	33
R	Bac à chaîne	34
	Bon de commande de pièces	37

A – Boîtier

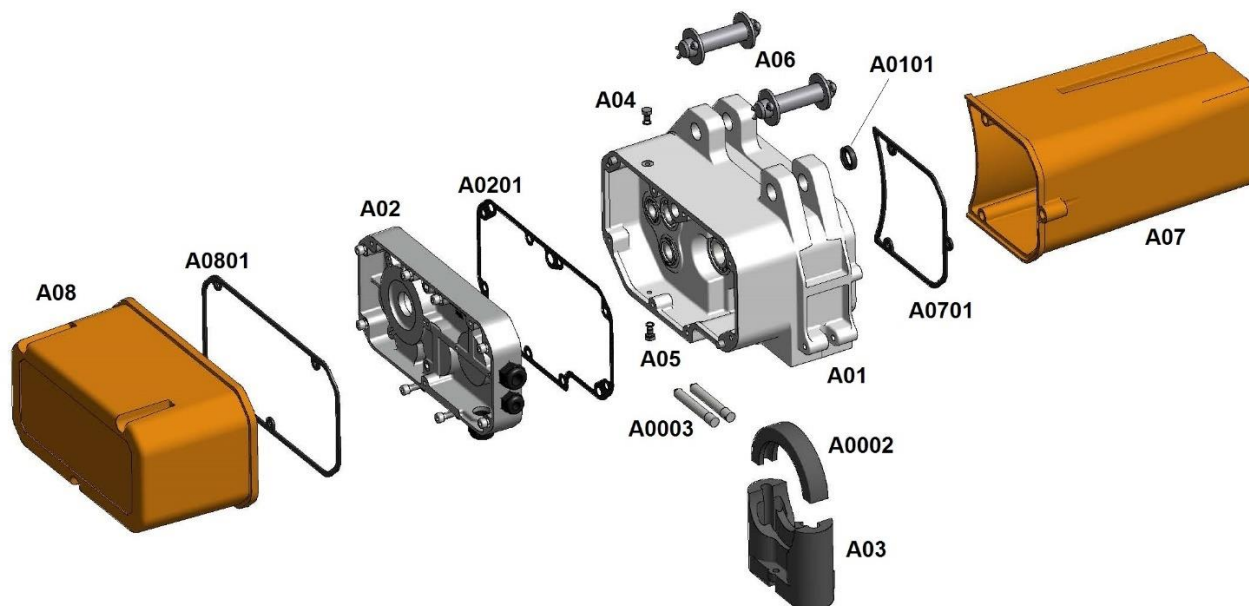

Modèle STAR 02../..

Code	Dénomination	Version	N° de commande
A01	Boîtier cpl.	STAR 02../..	03 9 020 52 001/1
		STAR 020/50	03 9 020 50 001/1
A0101	Bague à lèvres en caoutchouc		64 10012 02407
A02	Couvercle réducteur cpl.	STAR 02../..	03 9 020 52 002/1
		STAR 020/50	03 9 020 50 002/1
A0201	Joint périphérique couvercle réducteur		03 0 020 50 035/0
A03	Guide-chaîne cpl.	avec commutateur de fin de course	03 9 020 50 008/1
		sans commutateur de fin de course	03 8 020 50 008/0
A04	Boulon de remplissage d'huile cpl.		01 9 00A 200/0
A05	Boulon de vidange d'huile cpl.		01 9 00A 201/0
A06	Jeu de chevilles de suspension		03 9 020 50 210/0
A07	Couvercle commande cpl.		03 9 020 50 005/0
A0701	Joint pour le couvercle de commande		03 0 020 50 039/0
A08	Couvercle côté réducteur cpl.		03 9 020 50 004/0
A0801	Joint pour le couvercle côté train d'entraînement		03 0 020 50 036/0
A0002	Serre-chaîne		53 S0020 02900
A0003	Étrier de fixation de l'extrémité de la chaîne		23 S0020 00070

Modèle STAR 03../.

Code	Dénomination	Version	N° de commande
A01	Boîtier cpl.		03 9 020 52 001/1
A0101	Bague à lèvres en caoutchouc		64 10012 02407
A02	Couvercle réducteur cpl.		03 9 020 52 002/1
A0201	Joint périphérique couvercle réducteur		03 0 020 50 035/0
A03	Guide-chaîne cpl.	avec commutateur de fin de course	03 9 030 50 008/1
	Guide-chaîne cpl.	sans commutateur de fin de course	03 8 030 50 008/0
A04	Boulon de remplissage d'huile cpl.		01 9 00A 200/0
A05	Boulon de vidange d'huile cpl.		01 9 00A 201/0
A06	Jeu de chevilles de suspension		03 9 020 50 210/0
A07	Couvercle commande cpl.		03 9 020 50 005/0
A0701	Joint pour le couvercle de commande		03 0 020 50 039/0
A08	Couvercle côté réducteur cpl.		03 9 020 50 004/0
A0801	Joint pour le couvercle côté train d'entraînement		03 0 020 50 036/0
A0002	Serre-chaîne		53 S0030 02900
A0003	Étrier de fixation de l'extrémité de la chaîne		23 S0020 00070

Modèle STAR 05../.

Code	Dénomination	Version	N° de commande
A01	Boîtier cpl.	STAR 05../.	03 9 050 52 001/0
		STAR 051/52	03 9 051 52 001/0
A0101	Bague à lèvres en caoutchouc		64 10017 03207
A02	Couvercle réducteur cpl.	STAR 05../.	03 9 050 52 002/0
		STAR 051/52	03 9 051 52 002/0
A0201	Joint périphérique couvercle réducteur		03 0 050 50 035/0
A03	Guide-chaîne cpl.	avec commutateur de fin de course	03 9 050 50 008/1
	Guide-chaîne cpl.	sans commutateur de fin de course	03 8 050 50 008/0
A04	Boulon de remplissage d'huile cpl.		01 9 00A 200/0
A05	Boulon de vidange d'huile cpl.		01 9 00A 201/0
A06	Jeu de chevilles de suspension		03 9 070 50 210/0
A07	Couvercle commande cpl.		03 9 050 50 005/0
A0701	Joint pour le couvercle de commande		03 0 050 50 039/0
A08	Couvercle côté réducteur cpl.		03 9 050 50 004/0
A0801	Joint pour le couvercle côté train d'entraînement		03 0 050 50 036/0
A0002	Serre-chaîne		53 S0050 02900
A0003	Étrier de fixation de l'extrémité de la chaîne		23 S0020 00070

Modèle STAR 07../..

Code	Dénomination	Version	N° de commande
A01	Boîtier cpl.	STAR 07../..	03 9 070 51 001/0
		STAR 070/56	03 9 070 56 001/0
A0101	Bague à lèvres en caoutchouc		64 10017 03207
A02	Couvercle réducteur cpl.		03 9 070 51 002/0
A0201	Joint périphérique couvercle réducteur		03 0 050 50 035/0
A03	Guide-chaîne cpl.	avec commutateur de fin de course	03 9 070 50 008/1
	Guide-chaîne cpl.	sans commutateur de fin de course	03 8 070 50 008/0
A04	Boulon de remplissage d'huile cpl.		01 9 00A 200/0
A05	Boulon de vidange d'huile cpl.		01 9 00A 201/0
A06	Jeu de chevilles de suspension	STAR 07../..	03 9 070 50 210/0
		STAR 070/56	03 9 070 56 210/0
A07	Couvercle commande cpl.		03 9 050 50 005/0
A0701	Joint pour le couvercle de commande		03 0 050 50 039/0
A08	Couvercle côté réducteur cpl.		03 9 050 50 004/0
A0801	Joint pour le couvercle côté train d'entraînement		03 0 050 50 036/0
A0002	Serre-chaîne		53 S0070 02900
A0003	Étrier de fixation de l'extrémité de la chaîne		23 S0070 00070

Modèle STAR 09../..

Code	Dénomination	Version	N° de commande
A01	Boîtier cpl.		03 9 090 50 001/0
A0101	Bague à lèvres en caoutchouc		64 10020 03207
A02	Couvercle réducteur cpl.		03 9 090 50 002/0
		à partir du N° de fabrication 800000	03 9 090 50 002/1
A0202	Bague à lèvres en caoutchouc		64 10022 03507
A0201	Joint périphérique couvercle réducteur		03 0 090 50 035/0
A03	Guide-chaîne cpl.	avec commutateur de fin de course	03 9 090 50 008/1
	Guide-chaîne cpl.	sans commutateur de fin de course	03 8 090 50 008/0
A04	Boulon de remplissage d'huile cpl.		01 9 00A 200/0
A05	Boulon de vidange d'huile cpl.		01 9 00A 201/0
A06	Jeu de chevilles de suspension		03 9 090 50 210/0
A07	Couvercle commande cpl.	STAR 09../..	03 9 110 50 005/1
		STAR 091/57; 091/58	03 9 110 51 005/0
A0701	Joint pour le couvercle de commande		03 0 090 50 039/0
A08	Couvercle côté réducteur cpl.	STAR 09../..	03 9 090 50 004/1
		STAR 091/57; 091/58	03 9 090 20 004/1
A0801	Joint pour le couvercle côté train d'entraînement		03 0 090 50 036/0
A0002	Serre-chaîne		53 S0090 02900
A0003	Étrier de fixation de l'extrémité de la chaîne		03 2 090 50 007/0

Modèle STAR 11../.

Code	Dénomination	Version	N° de commande
A01	Boîtier cpl.		03 9 110 50 001/0
A0101	Bague à lèvres en caoutchouc		64 10020 03207
A02	Couvercle réducteur cpl.		03 9 110 50 002/0
		à partir du N° de fabrication 800000	03 9 110 50 002/1
A0202	Bague à lèvres en caoutchouc		64 10022 03507
A0201	Joint périphérique couvercle réducteur		03 0 110 50 035/0
A03	Guide-chaîne cpl.	avec commutateur de fin de course	03 9 110 50 008/1
	Guide-chaîne cpl.	sans commutateur de fin de course	03 8 110 50 008/0
A04	Boulon de remplissage d'huile cpl.		01 9 00A 200/0
A05	Boulon de vidange d'huile cpl.		01 9 00A 201/0
A06	Jeu de chevilles de suspension		03 9 110 50 210/0
A07	Couvercle commande cpl.	STAR 110/52, 110/54	03 9 110 50 005/1
		STAR 111/52, 111/54	03 9 110 51 005/0
A0701	Joint pour le couvercle de commande		03 0 090 50 039/0
A08	Couvercle côté réducteur cpl.		03 9 090 50 004/1
A0801	Joint pour le couvercle côté train d'entraînement		03 0 090 50 036/0
A0002	Serre-chaîne		53 S0110 02900
A0003	Étrier de fixation de l'extrémité de la chaîne		03 2 110 50 007/0

B – Frein

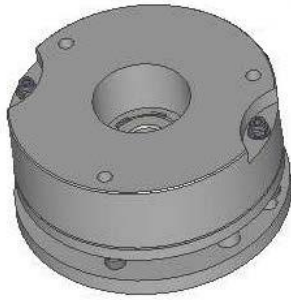

Modèle STAR 02../..

Code	Dénomination	Version	N° de commande
B01	Frein électromagnétique à ressort cpl.	STAR 02../..	17 70B06 04205
		STAR 020/01	17 70B06 04205

Modèle STAR 03../..

Code	Dénomination	Version	N° de commande
B01	Frein électromagnétique à ressort cpl.	STAR 03../..	17 70B06 04205
		STAR 030/52, 031/52	17 70B06 04205MS

Modèle STAR 05../..

Code	Dénomination	Version	N° de commande
B01	Frein électromagnétique à ressort cpl.	STAR 05../..	17 70B08 09205
		STAR 051/50, 051/52	17 70B08 06205
		STAR 050/01, 050/02	17 70B08 06205

Modèle STAR 07../..

Code	Dénomination	Version	N° de commande
B01	Frein électromagnétique à ressort cpl.	STAR 07../..	17 70B08 06205
		STAR 070/53, 070/56	17 70B08 09205
		STAR 070/01, 070/02	17 70B08 06205

Modèle STAR 09../..

Code	Dénomination	Version	N° de commande
B01	Frein électromagnétique à ressort cpl.	STAR 090/52, 091/51, 091/52	17 70B10 12205
		STAR 090/54, 090/55, 091/56, 091/57, 091/58	17 70B12 22205

Modèle STAR 11../..

Code	Dénomination	Version	N° de commande
B01	Frein électromagnétique à ressort cpl.	STAR 11../..	17 70B12 22205

C – Embrayage

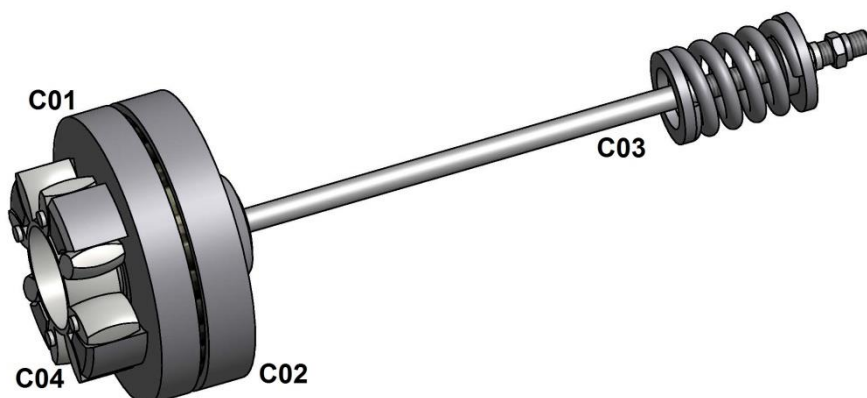

Modèle STAR 02../..

Code	Dénomination	Version	N° de commande
C01	Disque d'entraînement de l'embrayage cpl.		14 2 020 50 003/1
C02	Disque d'embrayage cpl.		14 9 020 50 005/0
C03	Jeux accessoires d'embrayage	STAR 02../..	14 9 020 50 010/0
		STAR 020/52; 021/52	14 9 020 52 010/0
C04	Disque à dents		54 00240 05502

Modèle STAR 03../..

Code	Dénomination	Version	N° de commande
C01	Disque d'entraînement de l'embrayage cpl.		14 2 020 50 003/1
C02	Disque d'embrayage cpl.		14 9 020 50 005/0
C03	Jeux accessoires d'embrayage	STAR 03../..	14 9 020 50 010/0
		STAR 030/52, 031/52	14 9 030 52 010/0
C04	Disque à dents		54 00240 05502

Modèle STAR 05../..

Code	Dénomination	Version	N° de commande
C01	Disque d'entraînement de l'embrayage cpl.		14 2 050 50 003/1
C02	Disque d'embrayage cpl.		14 9 050 50 005/0
C03	Jeux accessoires d'embrayage		14 9 050 50 010/0
C04	Disque à dents		54 00240 05502

Modèle STAR 07../..

Code	Dénomination	Version	N° de commande
C01	Disque d'entraînement de l'embrayage cpl.		14 2 050 50 003/1
C02	Disque d'embrayage cpl.		14 9 050 50 005/0
C03	Jeux accessoires d'embrayage		14 9 050 50 010/0
C04	Disque à dents		54 00240 05502

Modèle STAR 09../..

Code	Dénomination	Version	N° de commande
C01	Disque d'entraînement de l'embrayage cpl.		14 2 090 50 003/0
C02	Disque d'embrayage cpl.		14 9 090 50 005/0
		à partir du N° de fabrication 800000	14 9 090 50 005/1
C03	Jeux accessoires d'embrayage	STAR 09../..	14 9 090 50 010/0
		STAR 090/52, 091/51, 091/52	14 9 090 51 010/0
C04	Disque à dents		54 00380 09502
		à N° de fabrication D20758	54 00380 09502/ET

Modèle STAR 11../..

Code	Dénomination	Version	N° de commande
C01	Disque d'entraînement de l'embrayage cpl.		14 2 090 50 003/0
C02	Disque d'embrayage cpl.		14 9 090 50 005/0
		à partir du N° de fabrication 800000	14 9 090 50 005/1
C03	Jeux accessoires d'embrayage		14 9 090 50 010/0
C04	Disque à dents		54 00380 09502
		à N° de fabrication D20758	54 00380 09502/ET

Outil spécial

Code	Dénomination	Version	N° de commande
C05	Bit pour vis à tête aplatie (barre de traction)	STAR 02../.., 03../..	91 01000 00050
		STAR 05../.., 07../..	91 01000 00060
		STAR 09../.., 11../..	91 01000 00080

D – Arbre d'entraînement

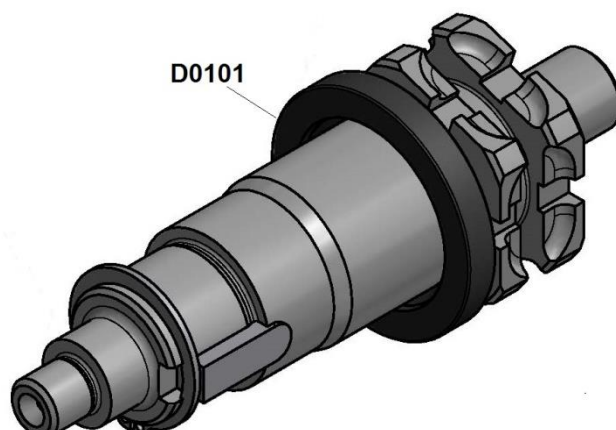

Modèle STAR 02../..

Code	Dénomination	Version	N° de commande
D01	Arbre d'entraînement de la chaîne cpl.		03 9 020 50 025/0
D0101	Bague à lèvres en caoutchouc		64 10035 05207
D0102	Bague à lèvres en caoutchouc		64 10012 02407
A0201	Joint périphérique couvercle réducteur		03 0 020 50 035/0

Modèle STAR 03../..

Code	Dénomination	Version	N° de commande
D01	Arbre d'entraînement de la chaîne cpl.		03 9 030 50 025/0
D0101	Bague à lèvres en caoutchouc		64 10035 05207
D0102	Bague à lèvres en caoutchouc		64 10012 02407
A0201	Joint périphérique couvercle réducteur		03 0 020 50 035/0

Modèle STAR 05../..

Code	Dénomination	Version	N° de commande
D01	Arbre d'entraînement de la chaîne cpl.		03 9 050 50 025/0
D0101	Bague à lèvres en caoutchouc		64 10045 07510
D0102	Bague à lèvres en caoutchouc		64010017 03207
A0201	Joint périphérique couvercle réducteur		03 0 050 50 035/0

Modèle STAR 07../..

Code	Dénomination	Version	N° de commande
D01	Arbre d'entraînement de la chaîne cpl.		03 9 070 50 025/0
D0101	Bague à lèvres en caoutchouc		64 10045 07510
D0102	Bague à lèvres en caoutchouc		64 10017 03207
A0201	Joint périphérique couvercle réducteur		03 0 050 50 035/0

Modèle STAR 09../..

Code	Dénomination	Version	N° de commande
D01	Arbre d'entraînement de la chaîne cpl.		03 9 090 50 025/0
		à partir du N° de fabrication 800000	03 9 090 50 025/1
D0101	Bague à lèvre en caoutchouc		64 10065 10010
D0102	Bague à lèvre en caoutchouc		64 10020 03207
		à partir du N° de fabrication 800000	64 10022 03507
D01001	Disque d'étanchéité		96 NJ000 00205NI
A0201	Joint périphérique couvercle réducteur		03 0 090 50 035/0

Modèle STAR 11../..

Code	Dénomination	Version	N° de commande
D01	Arbre d'entraînement de la chaîne cpl.		03 9 110 50 025/0
		à partir du N° de fabrication 800000	03 9 110 50 025/1
D0101	Bague à lèvre en caoutchouc		64 10085 12010
D0102	Bague à lèvre en caoutchouc		64 10020 03207
		à partir du N° de fabrication 800000	64 10022 03507
D01001	Disque d'étanchéité		96 NI000 00206NI
A0201	Joint périphérique couvercle réducteur		03 0 110 50 035/0

E – Chaîne

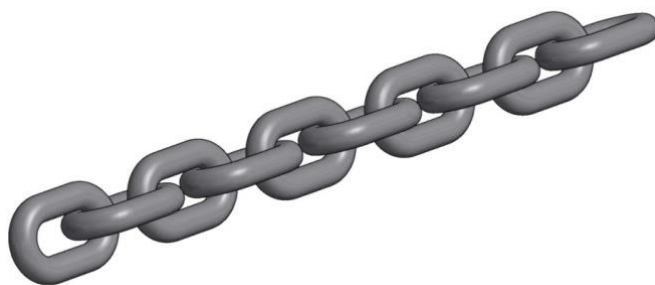

Modèle STAR 02../..

Code	Dénomination	Version	N° de commande
E01	Chaîne	4x12 mm	47 04012 00002V

Modèle STAR 03../..; STAR 05../..

Code	Dénomination	Version	N° de commande
E01	Chaîne	5,2x15 mm	47 05215 00002V

Modèle STAR 07../..

Code	Dénomination	Version	N° de commande
E01	Chaîne	7,2x21 mm	47 07221 00002V

Modèle STAR 09../..

Code	Dénomination	Version	N° de commande
E01	Chaîne	9x27 mm	47 09027 00002V

Modèle STAR 11../..

Code	Dénomination	Version	N° de commande
E01	Chaîne	11,3x31 mm	47 11331 00005V

F – Moteur

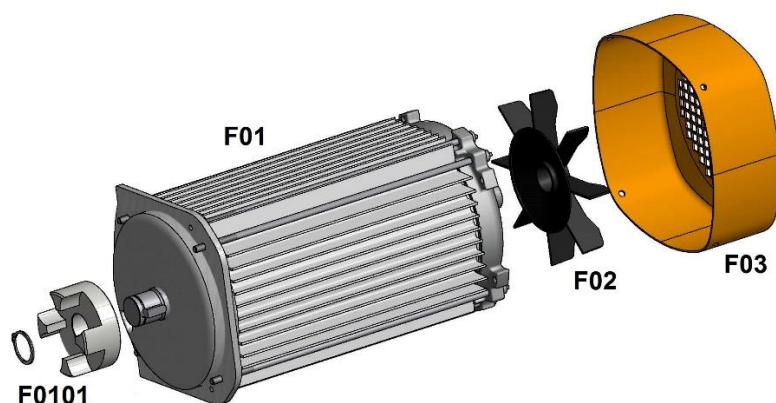

LIFTKET			
LIFTKET Hoffmann GmbH www.liftket.de ELEKTROKETTENZUG / ELECTRIC CHAIN HOIST Made in Germany			
Typ / Type 050/95	Fabrik-Nr. / Serial no. H35453	Baujahr / Fabr. year 07/2017	
S.W.L (kg) 500	1/1	5,2x15 mm	EN 818-7
(m/min) 18,0		FEM/ISO	1Bm/M3
		60% ED	240 S/h
KLOR 80G2	690 V;	50 Hz;	3 ph F; IP 55
1,5 kW		cos φ 0,90	
1,68 A		2850 min ⁻¹	



Modèle STAR 02../..

Code	Dénomination	Version	N° de commande
F01	Moteur cpl. 400V, 50Hz, 3ph (autres tensions sur demande)	63K20	42 9 063K20 000/0
		63G20	42 9 063G20 000/0
		63G8/2	42 9 063G82 000/0
F01	Moteur cpl. 230V, 1ph~	63G2	42 9 063G20E 000/0
F0101	Moyeu d'embrayage cpl.		14 9 020 50 001/0
F02	Aube ventilateur		53 S0055 00560
F03	Couvercle ventilateur pour le moteur		42 9 063K40 011/0

Modèle STAR 03../..

Code	Dénomination	Version	N° de commande
	Moteur cpl. 400V, 50Hz, 3ph (autres tensions sur demande)	63G2	42 9 063G20 000/0
		63G8/2	42 9 063G82 000/0
F0101	Moyeu d'embrayage cpl.		14 9 020 50 001/0
F02	Aube ventilateur		53 S0055 00560
F03	Couvercle ventilateur pour le moteur		42 9 063K40 011/0

Modèle STAR 05../.

Code	Dénomination	Version	N° de commande
F01	Moteur cpl. 400V, 50Hz, 3ph (autres tensions sur demande)	71G2	42 9 071G20 000/0
		71G4	42 9 071G40 000/0
		71G8/2	42 9 071G82 000/0
		80G8/2	42 9 080G82 000/0
F01	Moteur cpl. 230V, 1ph~	71G2	42 9 071G20E 000/0
F0101	Moyeu d'embrayage cpl.		14 9 050 50 001/0
F02	Aube ventilateur		53 S0055 00780
F03	Couvercle ventilateur pour le moteur		42 9 071G40 011/0

Modèle STAR 07../.

Code	Dénomination	Version	N° de commande
F01	Moteur cpl. 400V, 50Hz, 3ph (autres tensions sur demande)	71G2	42 9 071G20 000/0
		80G2	42 9 080G20 000/0
		80G8/2	42 9 080G82 000/0
	Moteur cpl. 230V, 1ph~	80G2	42 9 080G20E 000/0
F0101	Moyeu d'embrayage cpl.		14 9 050 50 001/0
F02	Aube ventilateur		53 S0055 00780
F03	Couvercle ventilateur pour le moteur		42 9 071G40 011/0

Modèle STAR 09../.

Code	Dénomination	Version	N° de commande
F01	Moteur cpl. 400V, 50Hz, 3ph (autres tensions sur demande)	90L2	42 9 090L20 000/0
		90L4	42 9 090L40 000/0
		90L8/2	42 9 090L82 000/0
		100L8/2	42 9 100L82 000/0
		100LV8/2	42 9 100V82 000/0
F0101	Moyeu d'embrayage cpl.		14 9 090 50 001/0
F0102	Aube ventilateur	90L2, 90L4, 90L8/2	53 S0055 00900
		100L8/2, 100LV8/2	53 S0055 01000
F0103	Couvercle ventilateur pour le moteur	90L2, 90L4, 90L8/2	42 9 090L20 011/0
		100L8/2, 100LV8/2	42 9 100V82 011/0

Modèle STAR 11../.

Code	Dénomination	Version	N° de commande
F01	Moteur cpl. 400V, 50Hz, 3ph (autres tensions sur demande)	100S2	42 9 100S20 000/0
		100LV8/2	42 9 100V82 000/0
F0101	Moyeu d'embrayage cpl.		14 9 090 50 001/0
F0102	Aube ventilateur		53 S0055 01000
F0103	Couvercle ventilateur pour le moteur		42 9 100V82 011/0

Outil spécial

Code	Dénomination	N° de commande
F0104	Bit pour vis à tête aplatie (Barre de traction)	91 01000 00060

G – Commande directe

Commande directe 400V, 3ph complet

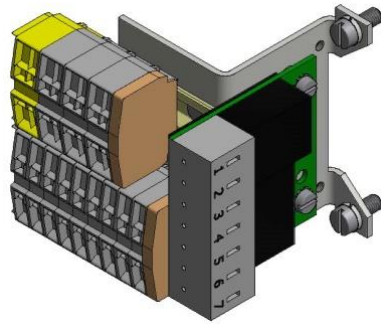

Code	Dénomination	Version	N° de commande
G01	Commande directe cpl.	une vitesse de levage	10 9 020 50 000/1

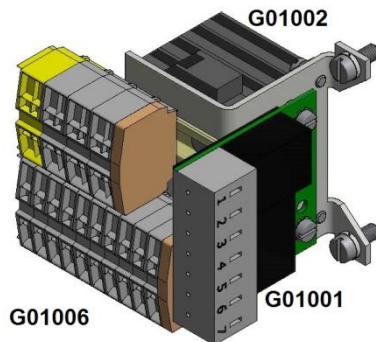

Code	Dénomination	Version	N° de commande
G01	Commande directe cpl.	deux vitesses de levage	10 9 021 50 000/0

Commande directe 230V, 1ph complet

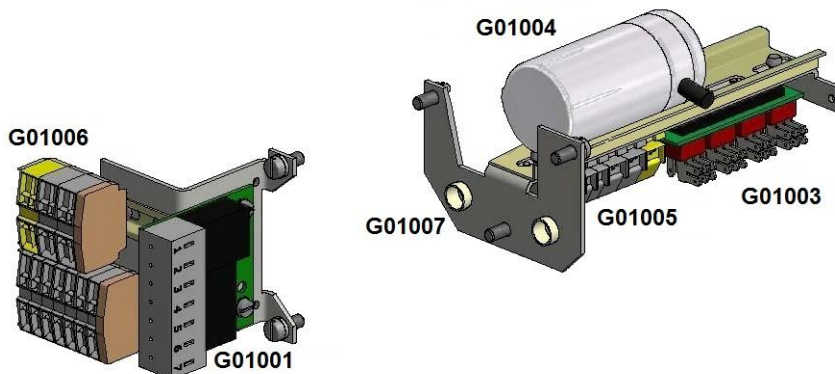



















































Code	Dénomination	Version	N° de commande
G01	Commande directe cpl.	STAR 020/0..	10 9 020 02 000/0
		STAR 050/0..	10 9 050 01 000/0
		STAR 070/0..	10 9 070 01 000/0











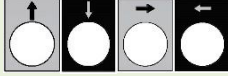

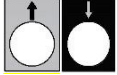
Composant

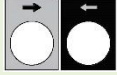
Code	Dénomination	Version	N° de commande
G01001	Redresseur		20 00040 00040F
G01002	Relais auxiliaire de frein		74 3LC1S K0624
	Relais de puissance	Type 1 – 115 spires	11 0 10D LC1/0
		Type 2 – 455 spires	11 0 10A LC1/0
		Type 3 – 66 spires	11 0 090 15 LC1/0
		Type 4 – 197 spires	11 0 050 00 LC1/0
G01003	L'électronique de déclenchement 230V, 1ph~		74 40060 02220
G01004	Condensateur 230V, 1ph~	STAR 020/01	20 00100 00041
		STAR 050/01	20 00100 00060
		STAR 070/01	20 00100 00125
G01005	Jeu de bornes (côté moteur)		11 9 020 50 500/0
G01006	Jeu de bornes (côté frein)	STAR 020/..	11 9 020 01 500/0
		STAR 050/.. - 111/..	11 9 050 50 500/0
G01007	Bouchon de fermeture		53 SA000 00203

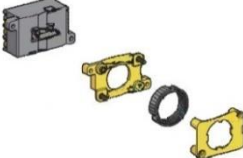











































Boîte à boutons pendante complet

Code	Dénomination	Symbol / Fonction	N° de commande
G02	Boîte à boutons pendante	 	81 B0100 00000
		  	81 B0100 000NH
		 	81 B0100 AK000
		pour les palans avec 1ph	
		  	81 B0100 AK0NH
		pour les palans avec 1ph	
		   	81 B0101 00000
		    	81 B0101 000NH
		   	81 B0102 00000
		    	81 B0102 000NH
		 	81 B0200 00000
		  	81 B0200 000NH
		   	81 B0201 00000
		    	81 B0201 000NH
		   	81 B0202 00000
		    	81 B0202 000NH

Boîte à boutons pendante / Composant

Code	Dénomination	Image	Symbol / Fonction	N° de commande
G0202	Inserts commutateur		 à 3,0 kW	81 XES0D 02201
			 pour les palans avec 1ph	81 XES0D 02241
			 à 2,0 kW	81 XES0D 01191
			 à 2,2 kW	81 XES0D 01291
				81 XAC0S 00499
G0203	Bouton d'arrêt d'urgence			81 ZA2BS 00054
G0204	Pièces en caoutchouc pour les endroits de commutation pour fonctions à une vitesse		Blanc	81 XAC0B 09111
			Noir	81 XAC0B 09112
	Pièces en caoutchouc pour les endroits commutateur des fonctions deux vitesses		Blanc	81 XAC0B 09211
			Noir	81 XAC0B 09212

Boîte à boutons pendante / câbles de commande

Code	Dénomination	Symbol / Fonction		N° de commande
G0201	Câbles de commande	 	7x1,5	45 0YMH0 07015
		  	7x1,5	45 0YMH0 07015
		   	8x1,5	45 0YMH0 08015
		    	8x1,5	45 0YMH0 08015
		   	12x1,5	45 0YMH0 12015
		    	12x1,5	45 0YMH0 12015
		 	7x1,5	45 0YMH0 07015
		  	7x1,5	45 0YMH0 07015
		   	10x1,5	45 0YMH0 10015
		    	10x1,5	45 0YMH0 10015
		   	12x1,5	45 0YMH0 12015
		    	12x1,5	45 0YMH0 12015

H – Commande à circuit auxiliaire

Commande à circuit auxiliaire 400V / 24V / 3ph complet

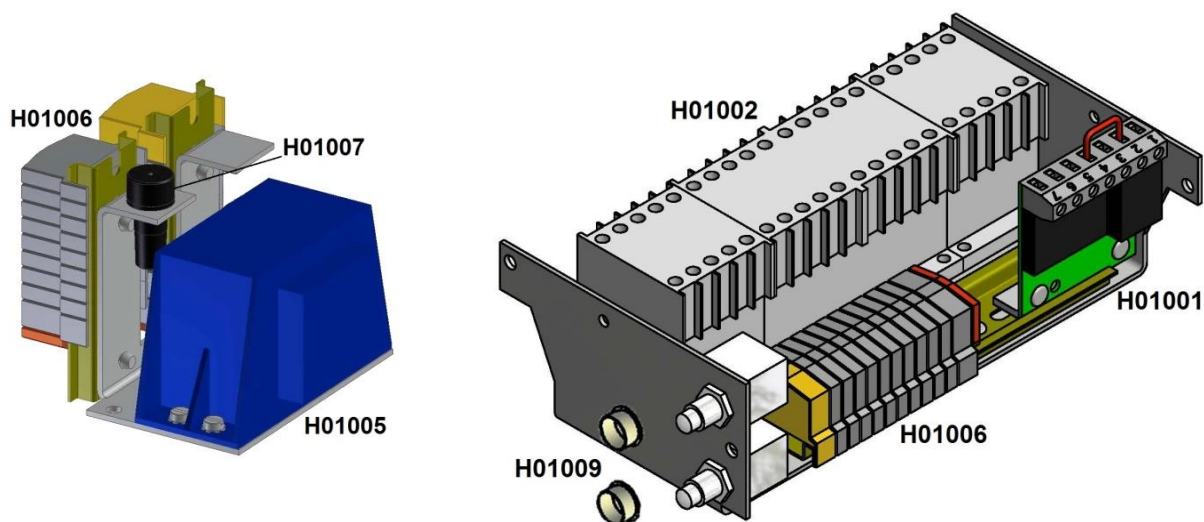

Code	Vitesse		Arrêt d'urgence		Interrupteur de fin de course	
	un	deux	par	sans	par	sans
H0101	x		x			x
H0102	x		x		x	
H0103	x			x		x
H0104	x			x	x	
H0105		x	x			x
H0106		x	x		x	
H0107		x		x		x
H0108		x		x	x	

Code	STAR 02../.., 03../..	STAR 05../..	STAR 07../..
H0101	11 2 020 011N 00/4	11 2 050 011N 00/4	11 2 070 011N 00/4
H0102	11 2 020 011NE 00/4	11 2 050 011NE 00/4	11 2 070 011NE 00/4
H0103	11 2 020 011 00/4	11 2 050 011 00/4	11 2 070 011 00/4
H0104	11 2 020 011 E 00/4	11 2 050 011 E 00/4	11 2 070 011 E 00/4
H0105	11 2 021 011N 00/4	11 2 051 011N 00/4	11 2 071 011N 00/4
H0106	11 2 021 011NE 00/4	11 2 051 011NE 00/4	11 2 071 011NE 00/4
H0107	11 2 021 011 00/4	11 2 051 011 00/4	11 2 071 011 00/4
H0108	11 2 021 011 E 00/4	11 2 051 011 E 00/4	11 2 071 011 E 00/4

Code	STAR 09../..	STAR 11../..
H0101	11 2 090 011N 00/4	11 2 110 011N 00/4
H0102	11 2 090 011NE 00/4	11 2 110 011NE 00/4
H0103	11 2 090 011 00/4	11 2 110 011 00/4
H0104	11 2 090 011 E 00/4	11 2 110 011 E 00/4
H0105	11 2 091 011N 00/4	11 2 111 011N 00/4
H0106	11 2 091 011NE 00/4	11 2 111 011NE 00/4
H0107	11 2 091 011 00/4	11 2 111 011 00/4
H0108	11 2 091 011 E 00/4	11 2 111 011 E 00/4

Commande à circuit auxiliaire 230V / 24V / 1ph complet

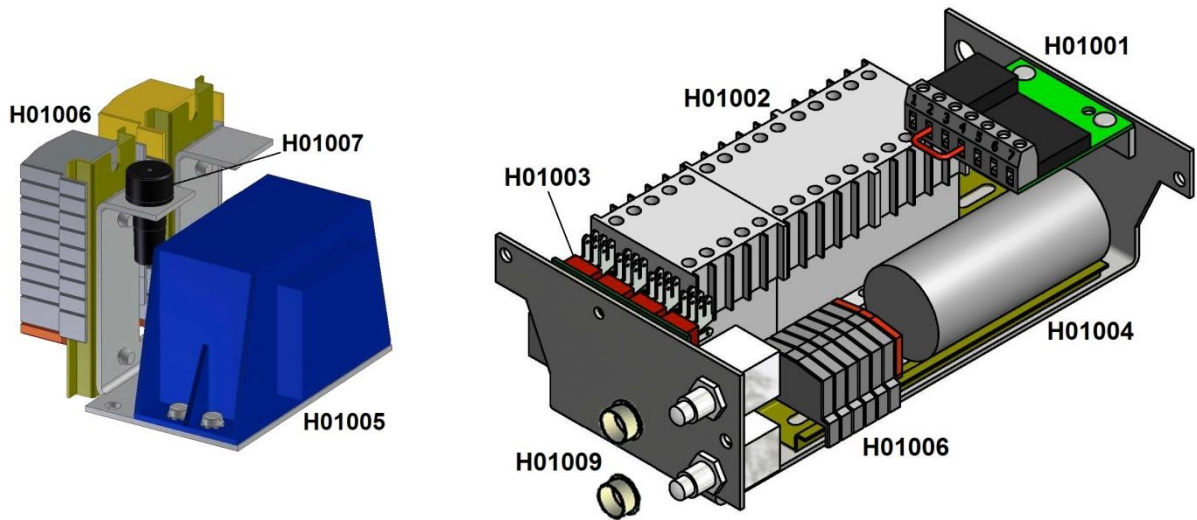















































Code	Arrêt d'urgence		Interrupteur de fin de course	
	par	sans	par	sans
H0109	x			x
H0110	x		x	
H0111		x		x
H0112		x	x	

Code	STAR 02../..	STAR 05../..	STAR 07../..
H0109	11 2 020 101N 00/1	11 2 050 101N 00/1	11 2 070 101N 00/1
H0110	11 2 020 101NE 00/1	11 2 050 101NE 00/1	11 2 070 101NE 00/1
H0111	11 2 020 101 00/1	11 2 050 101 00/1	11 2 070 101 00/1
H0112	11 2 020 101 E 00/1	11 2 050 101 E 00/1	11 2 070 101 E 00/1















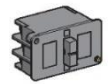

Composant

Code	Dénomination	Version	N° de commande
H01001	Redresseur		20 00040 00040F
H01002	Contacteur K1,	STAR 020/..., 021/...; STAR 030/..., 031/...	74 3DSL3 01024UL à 02/16
	Contacteur K2, K3	STAR 020/..., 021/...; STAR 030/..., 031/...	74 3B005 10024 de 03/16
	Contacteur K4	STAR 050/... - 110/...; STAR 051/... - 111/...	74 3LC1K 91024
H01003	L'électronique de déclenchement 230V, 1ph~	STAR 020/..., 021/...; STAR 030/..., 031/...	74 3DSL3 10024 à 02/16
		STAR 020/..., 021/...; STAR 030/..., 031/...	74 3BW05 10024 de 03/16
		STAR 050/... - 110/...; STAR 051/... - 111/...	74 3LC2K 91024
H01004	Condensateur	STAR 021/..., 031/... STAR 051/..., 071/...; 091/..., 111/...	74 3DSL3 22024UL à 02/16 74 3B005 22024 de 03/16
H01005	Transformateur 230-400V/24V	STAR 051/..., 071/...; 091/..., 111/... STAR 020/0.. - STAR 070/0..	74 3LC1K 98024
H01006	Jeu de bornes	STAR 020/0.. STAR 050/0.. STAR 070/0..	20 00100 00041 20 00100 00060 20 00100 00125
H01007	Porte-fusible	STAR 020/..., 021/...; STAR 030/..., 031/...	88 00400 UI024
		STAR 050/... - 110/...; STAR 051/... - 111/...	88 00400 EI024
H01008	Fusible	STAR 020/..., 021/...; STAR 030/..., 031/...	11 9 020 50 500/0
		STAR 050/... - 110/...; STAR 051/... - 111/...	11 9 050 50 500/0
H01009	Bouchon de fermeture	primaire	20 00060 00080
		secondaire	20 00060 00086
		1,25 A	20 00060 00082
			53 SA000 00202



























Boîte à boutons pendante complet

Code	Dénomination	Symbol / Fonction	N° de commande
H02	Boîte à boutons pendante	 	81 A0100 00000
		  	81 A0100 000NH
		   	81 A0101 00000
		    	81 A0101 000NH
		   	81 A0102 00000
		    	81 A0102 000NH
		 	81 A0200 00000
		  	81 A0200 000NH
		   	81 A0201 00000
		    	81 A0201 000NH
		   	81 A0202 00000
		    	81 A0202 000NH

Boîte à boutons pendante / Composant

Code	Dénomination		Symbol / Fonction	N° de commande
H0202	Inserts commutateur			81 ZB2BE 00101
				
				81 ZB2BE 00201
				
				81 XEN0G 01191
				
H0203	Bouton d'arrêt d'urgence			81 ZB2BE 00102
				81 ZA2BS 00834
H0204	Pièces caoutchouc pour les endroits commutateur		Blanc	81 XAC0A 09411
			Noir	81 XAC0A 09412

Boîte à boutons pendante / câbles de commande

Code	Dénomination	Symbol / Fonction		N° de commande
H0201	Câbles de commande	 	4G1,5	45 0H070 04G15
		  	5G1,5	45 0H070 05G15
		   	7G1,5	45 0YMH0 07G15
		    	7G1,5	45 0YMH0 07G15
		   	7G1,5	45 0YMH0 07G15
		    	12G1,5	45 0H070 12G15
		 	5G1,5	45 0H070 05G15
		  	7G1,5	45 0YMH0 07G15
		   	7G1,5	45 0YMH0 07G15
		    	12G1,5	45 0H070 12G15
		   	12G1,5	45 0H070 12G15
		    	12G1,5	45 0H070 12G15

J – Interrupteur de fin de course

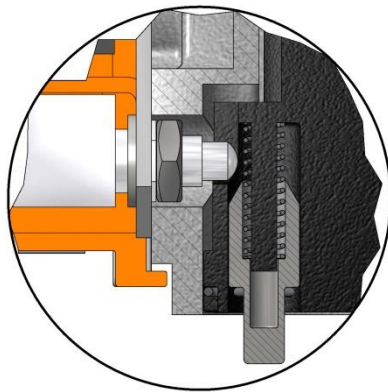
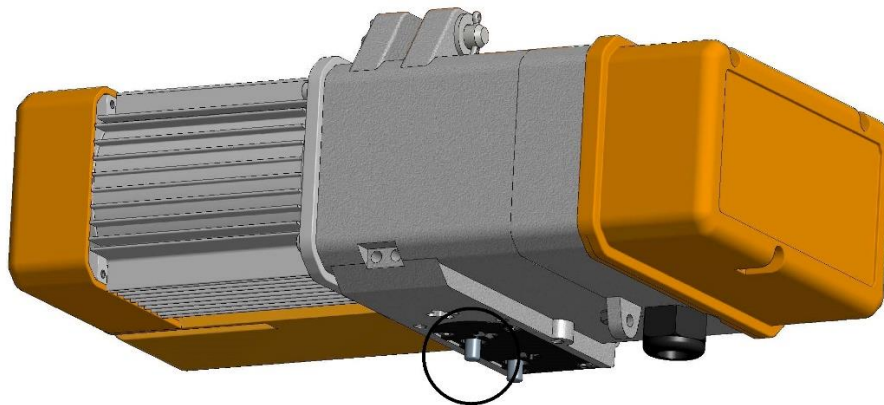

J01



J02

Code	Dénomination	Version	N° de commande
J01	Interrupteur de fin de course électrique cpl.		46 9 020 50 217/0
J02	Goupille interrupteur de fin de course, cpl.	STAR 02../.., 03../..	46 9 020 50 300/1
		STAR 05../.., 07../..	46 9 050 50 300/1
		STAR 09../..	46 9 090 50 300/1
		STAR 11../..	46 9 110 50 300/1

M - Œillet de suspension

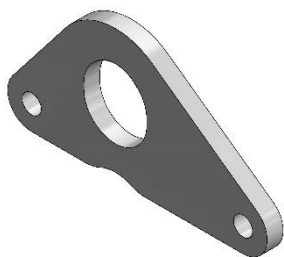

M01

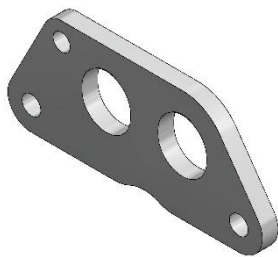

M02



M03

Code	Dénomination	Version		N° de commande		
M01	Œillet de suspension à un trou	STAR 02../.., 030/50	500 kg	55 0 020 50 003/0		
		STAR 030/..	1000 kg	55 0 030 50 004/1		
		STAR 05../..	1000 kg	55 0 050 50 002/0		
		STAR 07../..	2000 kg	55 0 070 50 004/0		
		STAR 070/56	2500 kg	55 0 070 56 004/0		
		STAR 09../..	3200 kg	55 0 090 50 004/0		
		STAR 11../..	6300 kg	55 0 110 50 003/0		
M02	Œillet de suspension à deux trou	STAR 02../.., 030/50	500 kg	55 0 020 50 002/1		
		STAR 030/..	1000 kg	N S1 S2	55 0 030 50 001/0 55 0 030 50 002/0 55 0 030 50 003/0	
		STAR 05../..	500 kg		55 0 070 50 001/0	
		STAR 050/53	1000 kg	N S1 S2	55 0 070 50 001/0 55 0 070 50 002/0 55 0 070 50 003/0	
		STAR 07../..	2000 kg	N S1 S2	55 0 070 50 001/0 55 0 070 50 002/0 55 0 070 50 003/0	
		STAR 070/56	2500 kg	N S1 S2	55 0 070 56 001/0 55 0 070 56 002/0 55 0 070 56 003/0	
		STAR 09../..	3200 kg	N S1 S2	55 0 090 50 001/0 55 0 090 50 002/0 55 0 090 50 003/0	
		STAR 11../..	6300 kg	N S1 S2	55 0 110 50 001/0 55 0 110 50 001/0 55 0 110 50 002/0	
		M03	Jeu de chevilles de suspension	STAR 02../.., 03../..		03 9 020 50 210/0
				STAR 05../.., 07../..		03 9 070 50 210/0
				STAR 070/56		03 9 070 56 210/0
				STAR 09../..		03 9 090 50 210/0
				STAR 11../..		03 9 110 50 210/0

N - Suspension à crochet



N01



N0101



N02

Code	Dénomination	Version		N° de commande
N01	Suspension à crochet	STAR 02../.., 03../..	rotative	56 2 020 50 SW0/0
			non rotative	56 2 020 51 SW0/0
		STAR 05../..	rotative	56 2 050 50 SW0/0
			non rotative	56 2 050 51 SW0/0
		STAR 07../..	rotative	56 2 070 50 SW0/0
			non rotative	56 2 070 51 SW0/0
		STAR070/56	rotative	56 2 070 56 SW0/0
			non rotative	56 2 070 57 SW0/0
		STAR 09../..	rotative	56 2 090 50 SW0/0
			non rotative	56 2 090 51 SW0/0
		STAR 11../..	rotative	56 2 110 50 SW0/0
			non rotative	56 2 110 51 SW0/0
N0101	Linguet anti-débloccage	STAR 02../.. – 05../..		20 9 020 50 003/0
				20 9 070 50 003/1
		STAR 09../..		20 9 090 50 003/0
		STAR 11../..		20 9 110 50 003/1
N02	Jeu de chevilles	STAR 02../.., 03../..		03 9 020 50 210/0
				03 9 070 50 210/0
		STAR 07../..		03 9 070 50 210/0
				03 9 070 56 210/0
		STAR 09../..		03 9 090 50 210/0
		STAR 11../..		03 9 110 50 210/0

O - Moufle à crochet

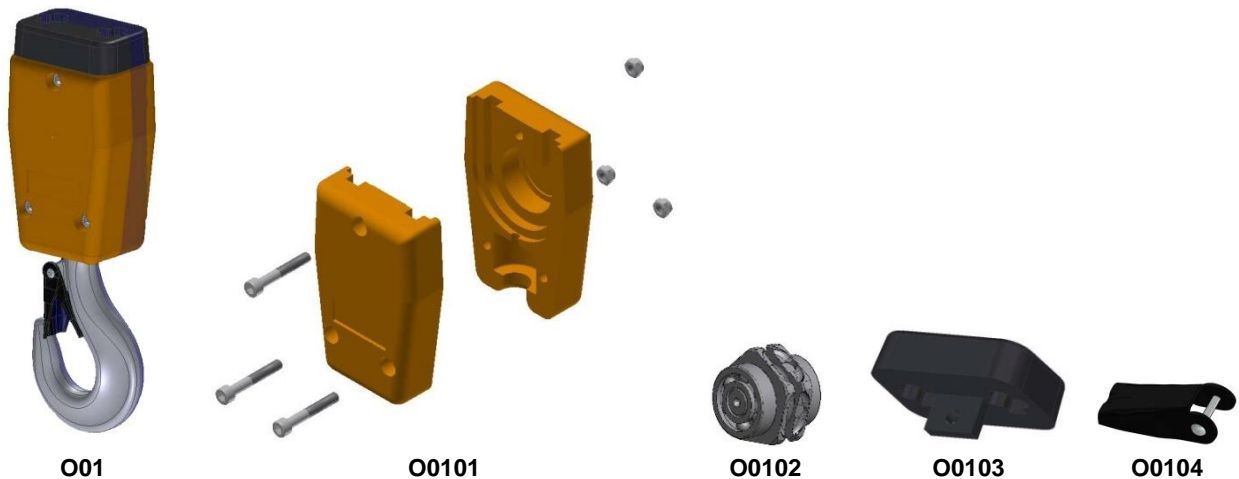

Code	Dénomination	Version	N° de commande	
O01	Moufle à crochet cpl.	4x12	20 2 020 50 000/0	
		5,2x15	20 2 030 50 000/0	
		7,2x21	2000 kg	20 2 070 50 000/0
			2500 kg	20 2 070 56 000/0
		9x27		20 2 090 50 000/1
O0101	Moufle à crochet, boîtier cpl.	11,3x31	20 2 110 50 000/0	
		4x12, 5,2x15	20 9 020 50 001/0	
		7,2x21	20 9 070 50 001/2	
		9x27	20 9 090 50 001/1	
O0102	Noix de chaîne	11,3x31	20 9 110 50 001/0	
		4x12	20 2 020 50 005/0	
		5,2x15	20 2 030 50 005/0	
		7,2x21	2000 kg	20 2 070 50 005/0
			2500 kg	20 2 070 56 005/0
O0103	Butée en caoutchouc	9x27	20 2 090 50 005/0	
		11,3x31	20 2 110 50 005/0	
		4x12, 5,2x15	20 0 020 50 014/0	
		7,2x21	20 0 070 50 014/0	
			environ 05/2011	20 0 070 50 014/2
O0104	Linguet anti-déblocage cpl.	9x27	20 0 090 50 014/1	
		11,3x31	20 0 110 50 014/0	
		4x12, 5,2x15	20 9 020 50 003/0	
		7,2x21	20 9 070 50 003/1	
	9x27	20 9 090 50 003/0		
	11,3x31	20 9 110 50 003/1		

P - Crochet de levage

Modèle STAR 02../.. – 05../..



P01



P0101



P0102

Code	Dénomination	Version	N° de commande
P01	Crochet de levage Skeletto cpl.	4x12	15 2 020 50 000/0
		5,2x15	15 2 030 50 000/0
P0101	Butée en caoutchouc		35 S0015 00300
P0102	Linguet anti-déblocage cpl.	Skeletto R 012	15 9 020 50 003/1
		RSN 012	15 9 020 50 003/0

10/2015

Modèle STAR 07../..



P01



P0101



P0102

Code	Dénomination	Version	N° de commande
P01	Crochet de levage cpl.	7,2x21	15 2 070 50 000/3
P0101	Butée en caoutchouc		35 00015 00700
P0102	Linguet anti-déblocage cpl.		20 9 020 50 003/0

Modèle STAR 09../..

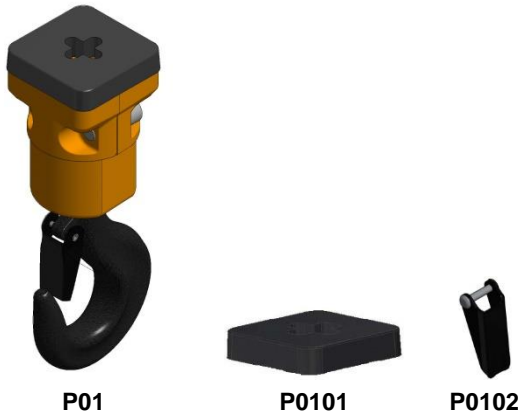

Code	Dénomination	Version	N° de commande
P01	Crochet de levage cpl.	9x27	15 2 090 50 000/1
P0101	Butée en caoutchouc		35 S0015 00901
P0102	Linguet anti-déblocage cpl.		20 9 070 50 003/1

Modèle STAR 11../..

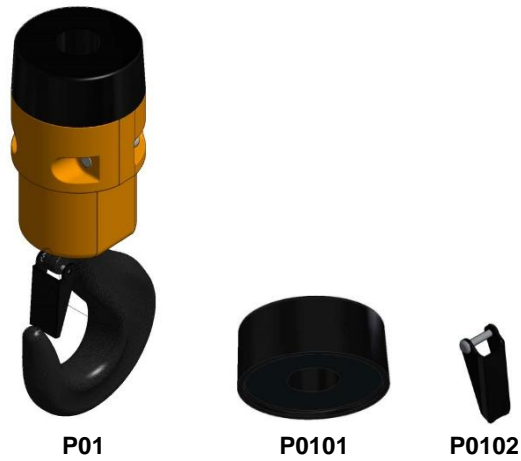

Code	Dénomination	Version	N° de commande
P01	Crochet de levage cpl.	11,3x31	15 2 110 50 000/0
P0101	Butée en caoutchouc		35 00015 01100
P0102	Linguet anti-déblocage cpl.		20 9 090 50 003/0

Q – Limiteur de levage

Modèle STAR 02../.. – 05../..



Q01



Q0101

Code	Dénomination	Version	N° de commande
Q01	Limiteur de levage cpl.	4x12	03 2 020 50 010/1
		5,2x15	03 2 030 50 010/1
Q0101	Butée en caoutchouc		35 S001 00300

Modèle STAR 07../..



Q01



Q0101

Code	Dénomination	Version	N° de commande
Q01	Limiteur de levage cpl.	7,2x21	03 2 070 50 010/0
Q0101	Butée en caoutchouc		35 S0001 00700

Modèle STAR 09../..



Q01



Q0101

Code	Dénomination	Version	N° de commande
Q01	Limiteur de levage cpl.	9x27	03 2 090 50 010/0
Q0101	Butée en caoutchouc		35 S0015 00901

Modèle STAR 11../..



Q01



Q0101

Code	Dénomination	Version	N° de commande
Q01	Limiteur de levage cpl.	11,3x31	03 2 110 50 010/1
Q0101	Butée en caoutchouc		35 S0015 00901

R - Bac à chaîne

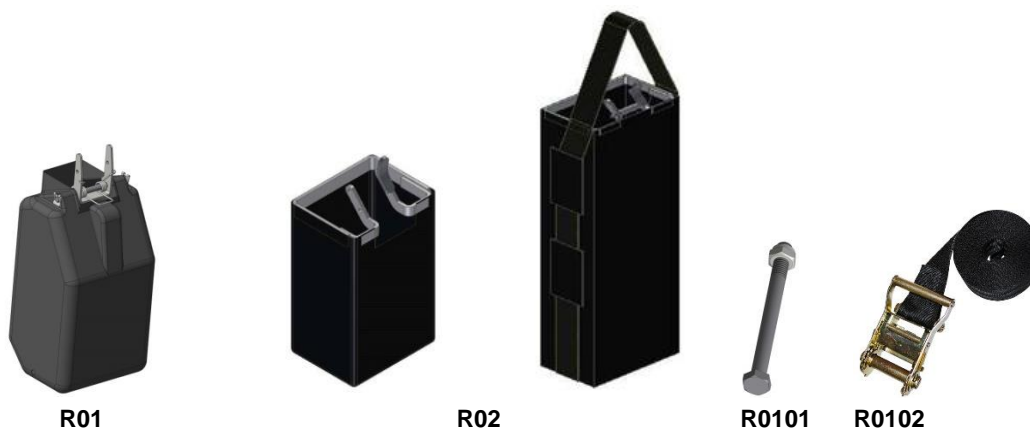

Code	Dénomination	Version	Chaîne/Mètre		N° de commande	
R01	Bac à chaîne en plastique	STAR 02../.., 03../..	4/12	5/8	30 2 020 50 000/1	
			4/16	5/10	30 2 030 50 000/1	
		STAR 05../.., 07../..	5/8	7/5	30 2 050 51 000/1	
			5/10	7/8	30 2 050 50 000/1	
R02	Bac à chaîne en textile	STAR 02../.., 03../..	4/10	5/8	30 2 030 50 000/2	
			4/20	5/18	30 2 030 51 000/0	
			4/30		30 2 030 52 000/0	
			4/40	5/25	30 2 030 53 000/0	
			4/50	5/40	30 2 030 54 000/0	
			4/80	5/60	30 2 030 56 000/0	
				5/70	30 2 030 57 000/0	
				5/90	30 2 030 58 000/0	
			STAR 05../.., 07../..	5/8		30 2 050 50 000/0
				5/18	7/8	30 2 050 51 000/0
		5/25		7/18	30 2 050 52 000/0	
		5/40		7/24	30 2 050 53 000/0	
		5/50			30 2 050 54 000/0	
		5/60		7/30	30 2 050 55 000/0	
		5/70			30 2 050 56 000/0	
		5/90			30 2 050 58 000/0	
				7/40	30 2 070 57 000/0	
				7/50	30 2 070 59 000/0	
			7/60	30 2 070 60 000/0		
		STAR 09../.., 11../..	9/10	11/6	30 2 110 50 000/0	
9/18	11/12		30 2 110 51 000/0			
9/30	11/20		30 2 110 54 000/0			
9/40	11/25		30 2 110 56 000/0			
9/50	11/30		30 2 110 57 000/0			
9/60	11/40		30 2 110 58 000/0			
9/75	11/50		30 2 110 59 000/0			
R0101	Vis de fixation	STAR 02../.., 03../..			30 9 020 50 100/0	
		STAR 05../.., 07../..			30 9 050 50 100/0	
		STAR 09../.., 11../..			30 9 110 50 100/0	
R0102	Set de sangle d'amarrage pour bac à chaîne	pour chaînes poids supérieur à 25 kg			30 9 030 54 012/0	

Bac à chaîne – Flip Bag



R03



R0301



R0302

Modèle STAR 02../.., 03../..

Code	Dénomination	Version	N° de commande	N° de commande
		Chaîne/Mètre	complet (R03)	séparé (R0301)
R03 /	Bac à chaîne Flip Bag	4/12 5/8	30 2 020 50 230/0	30 2 160 230/0
R0301		4/20 5/18	30 2 020 50 300/0	30 2 160 300/0
		4/40 5/25	30 2 020 50 400/0	30 2 160 400/0
		4/50 5/40	30 2 020 50 500/0	30 2 160 500/0
		4/80 5/60	30 2 020 50 600/0	30 2 160 600/0
		4/100 5/75	30 2 020 50 650/0	30 2 160 650/0
		5/100	30 2 020 50 700/0	30 2 160 700/0
R0302	Fixation			30 2 020 50 002/0

Modèle STAR 05../..

Code	Dénomination	Version	N° de commande	N° de commande
		Chaîne/Mètre	complet (R03)	séparé (R0301)
R03 /	Bac à chaîne Flip Bag	5/8 7/5	30 2 050 50 230/0	30 2 180 230/0
R0301		5/18 7/8	30 2 050 50 300/0	30 2 180 300/0
		5/25 7/18	30 2 050 50 400/0	30 2 180 400/0
		5/40 7/24	30 2 050 50 500/0	30 2 180 500/0
		5/60 7/30	30 2 050 50 600/0	30 2 180 600/0
		5/75 7/40	30 2 050 50 650/0	30 2 180 650/0
		5/100 7/50	30 2 050 50 700/0	30 2 180 700/0
		7/60	30 2 050 50 800/0	30 2 180 800/0
		7/70	30 2 050 50 900/0	30 2 180 900/0
R0302	Fixation			30 2 050 50 002/0

Modèle STAR 07../..

Code	Dénomination	Version	Chaîne/Mètre	N° de commande complet (R03)	N° de commande séparé (R0301)
R03 /	Bac à chaîne Flip Bag	5/8	7/5	30 2 070 50 230/0	30 2 180 230/0
R0301		5/18	7/8	30 2 070 50 300/0	30 2 180 300/0
		5/25	7/18	30 2 070 50 400/0	30 2 180 400/0
		5/40	7/24	30 2 070 50 500/0	30 2 180 500/0
		5/60	7/30	30 2 070 50 600/0	30 2 180 600/0
		5/75	7/40	30 2 070 50 650/0	30 2 180 650/0
		5/100	7/50	30 2 070 50 700/0	30 2 180 700/0
			7/60	30 2 070 50 800/0	30 2 180 800/0
			7/70	30 2 070 50 900/0	30 2 180 900/0
R0302	Fixation				30 2 070 50 002/0

Modèle STAR 09../..

Code	Dénomination	Version	Chaîne/Mètre	N° de commande complet (R03)	N° de commande séparé (R0301)
R03 /	Bac à chaîne Flip Bag	9/10		30 2 090 50 350/0	30 2 230 350/0
R0301		9/18		30 2 090 50 480/0	30 2 230 480/0
		9/30		30 2 090 50 600/0	30 2 230 600/0
		9/40		30 2 090 50 700/0	30 2 230 700/0
R0302	Fixation				30 2 090 50 002/0

Modèle STAR 11../..

Code	Dénomination	Version	Chaîne/Mètre	N° de commande complet (R03)	N° de commande séparé (R0301)
R03 /	Bac à chaîne Flip Bag	11/6		30 2 110 50 350/0	30 2 230 350/0
R0301		11/12		30 2 110 50 480/0	30 2 230 480/0
		11/20		30 2 110 50 600/0	30 2 230 600/0
		11/25		30 2 110 50 700/0	30 2 230 700/0
		11/30		30 2 110 50 800/0	30 2 230 800/0
R0302	Fixation				30 2 110 50 002/0

Bon de commande de pièces

N° de client
Adresse :
.....
.....
.....
.....
.....
.....

LIFTKET Hoffmann GmbH Wurzen
Dresdener Straße 64-68
04808 Wurzen / Allemagne



+49-3425-89 24-0
 +49-3425-89 24-99
 sales@liftket.de
 www.liftket.de

Electrique à chaîne

Modèle : Voltage : V Hz ph
N° d'usine : Commande : V

Art. Nr.	Dénomination	Version	N° de commande	Pièce / Mètre

.....
Lieu et date

.....
Signature

.....
Cachet de la maison

Au moment de la parution de cet imprimé, toutes les anciennes éditions perdent leur validité.
Sous réserve de modifications.